

g_dwind

INNOVATIVE DESIGN

MOST HYGENIC FUNCTION

FASTEST DRYING WITH FRESH AIR

GWHD10



GWHD11



FAST DRY TIME



HYGENIC HEPA FILTER



SMART MAINTENANCE SYSTEM



INTELLIGENT DIAGNOSIS SYSTEM

Highest hygienic standards with Change it yourself Filter (HEPA 13)

- **Innovated design**
Innovated and simple design to increase value
- **Economically feasible**
fastest drying with 1200 W
- **Patented Replaceable Filter System**
99,7% of all bacteria killed through patented HEPA13
- **Maximum convenience**
Dries hands faster than any other dryer
- **Environmental friendly**
Power saving clean technology, Less amount of carbon dioxide
- **Easy Maintenance**
Get rid of disposing, storage and personnel costs related to paper, Only clean once a day.
- **New features**
Water full sensor, filter change sensor, patented filter system
ABS fire proof material with ION PURE anti microbial treatment

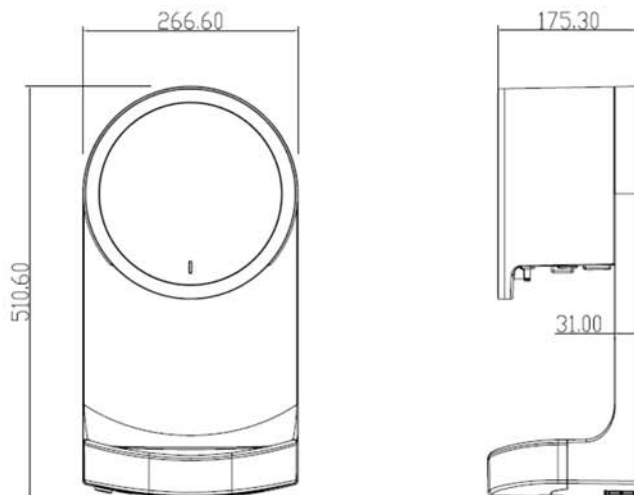

Mirro front

White & Silver

White & Black

Silver & Black

Customized

Voltage	AC 220~240V / AC 114~126 V
Frequency	50/60Hz
Power consumption	1200W
Motor	35,000 RPM/min Life ≥ 1000H (360,000 USES)
Air velocity	150m/s . 540 km/h
Drying time	10s
Noise	≤ 80dB
Air temperature	40—48 °C
Drain tray	Water Full Sensor
Filter	Patented HEPA 13 with Enzyme Two layer Filter changeable system Filter change indication lamp

Motor speed controller (optional)	2 steps motor speed adjustable
Material of exterior	ABS fire protection 94VO,PC, PMMA, Surface UV Spray. ION PURE Anti bacteria technology
Material of interior	PP,PA fire protection 94VO thermal resistance
Safety lock	Water Tank and Filter
Dimension	W266*D175*H510mm
Weight	About 5kg
Certifications	CE/GS, EMS,ETL,CCC
Operating Temperature	-20—60 °C;
Operating Humidity	20—80%
Thermal cut-off	≥ 105 °C OFF